An open book with a dark cover is shown from a top-down perspective. The pages are filled with faint, illegible text. Overlaid on the center of the book is the title of the presentation in a large, dark red, serif font.

# Understanding Metalanguage Integration by Renarration

Dr. Vadim Zaytsev, Universiteit van Amsterdam @ GEMOC'14

@grammarware

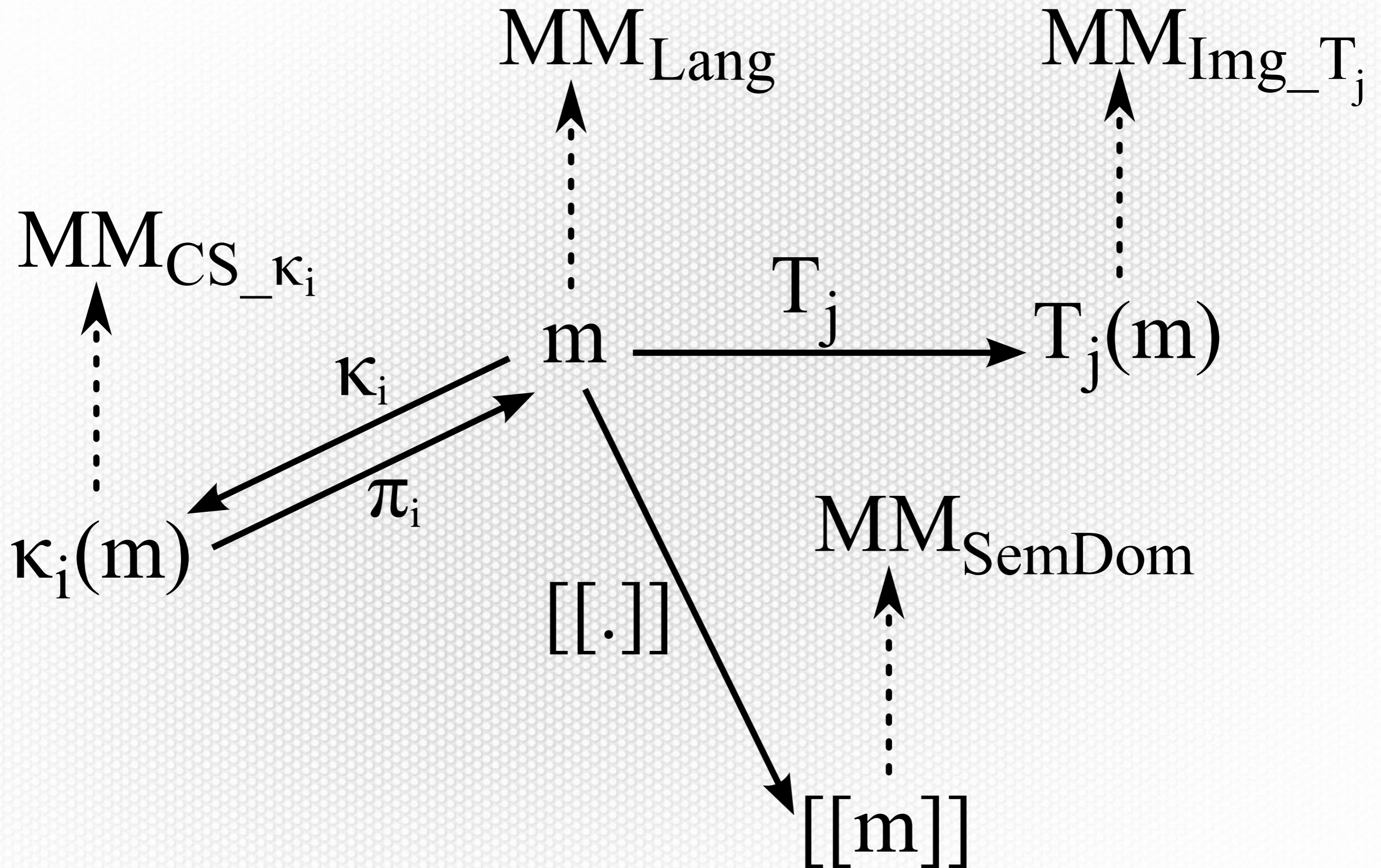





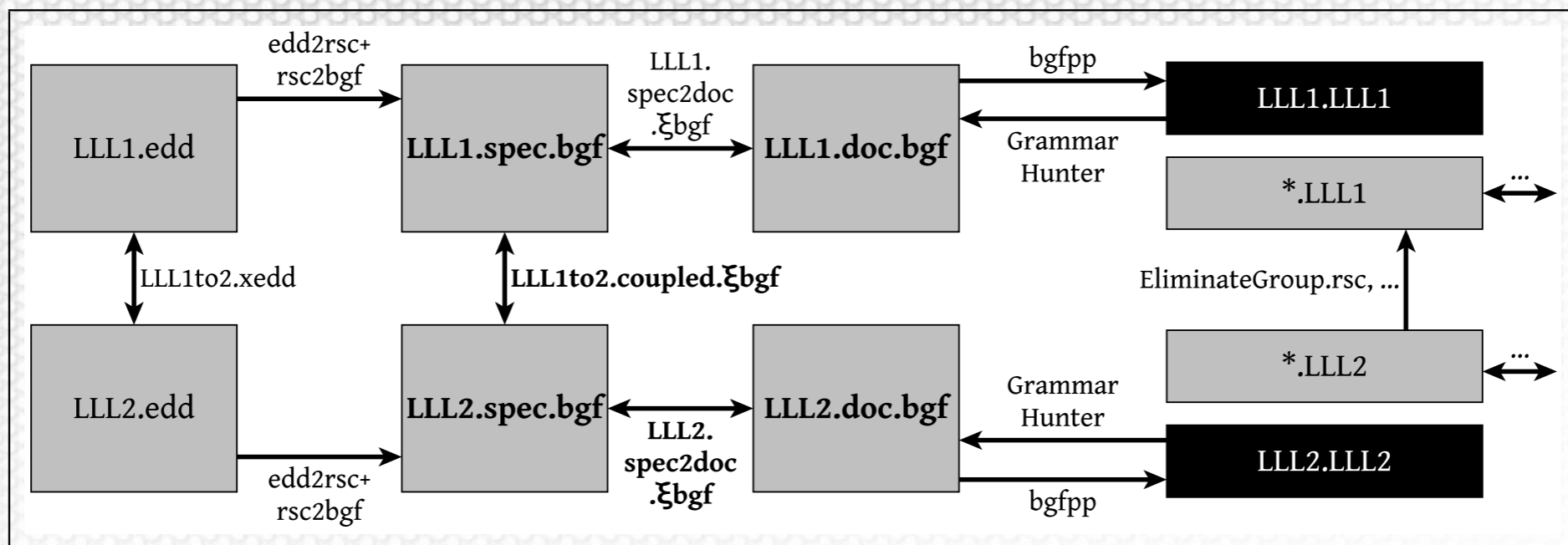
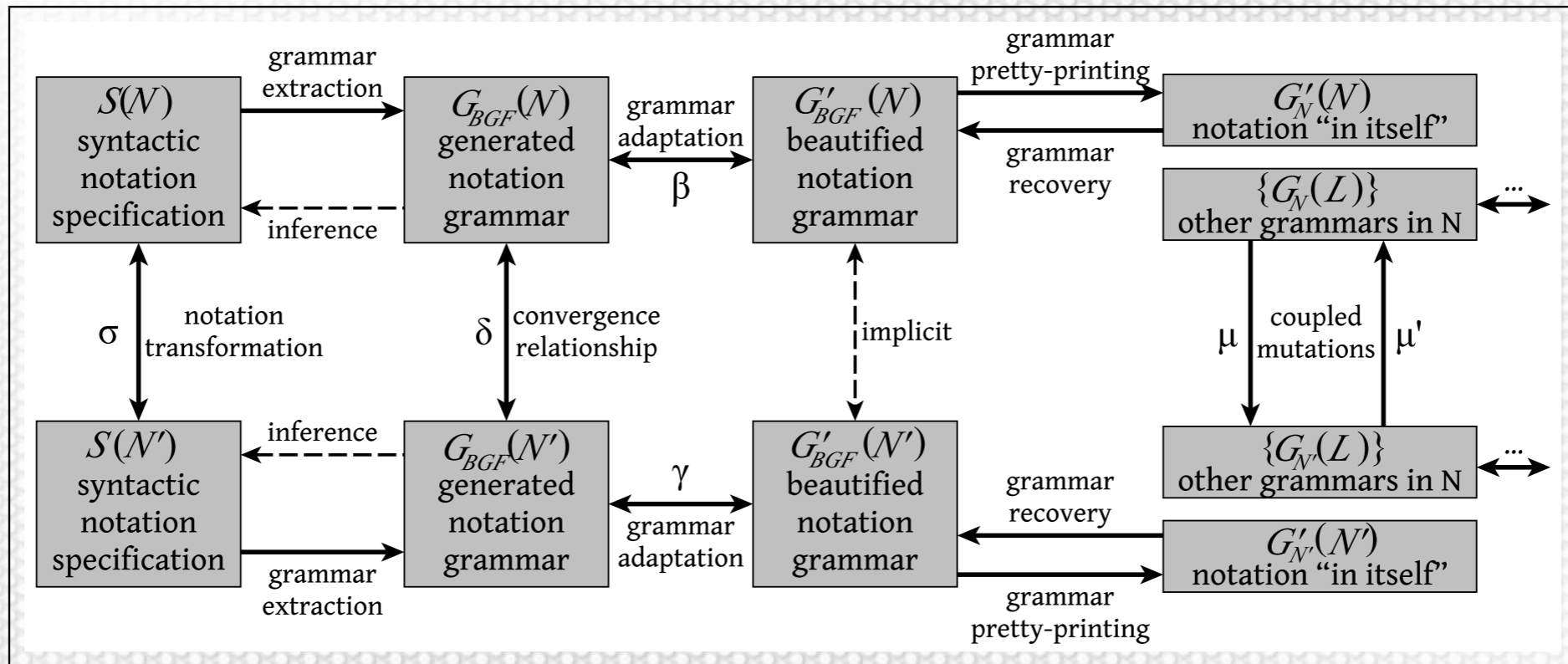
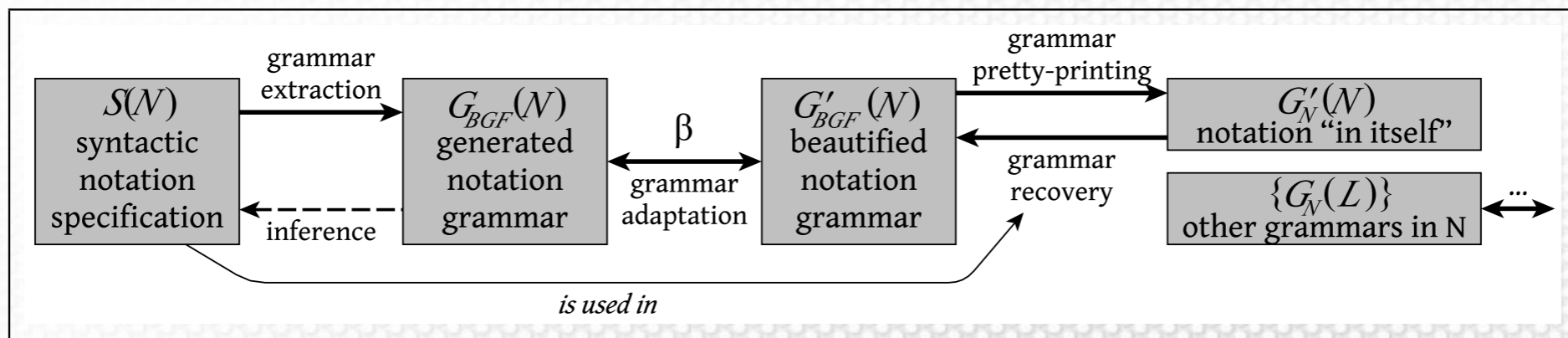

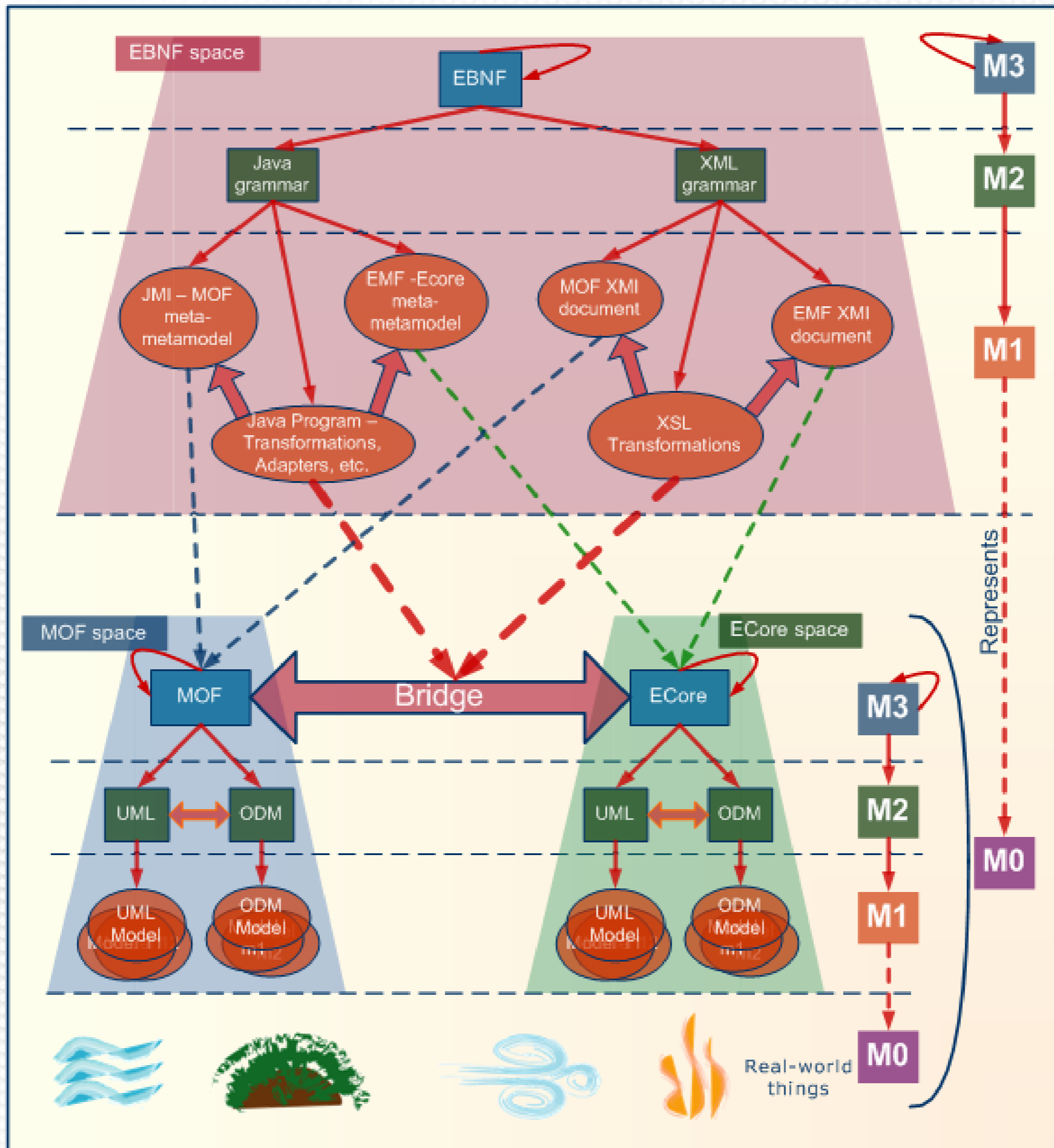

Djurić, Gašević, Devedžić. The Tao of Modeling Spaces. JOT 5(8). 2006.

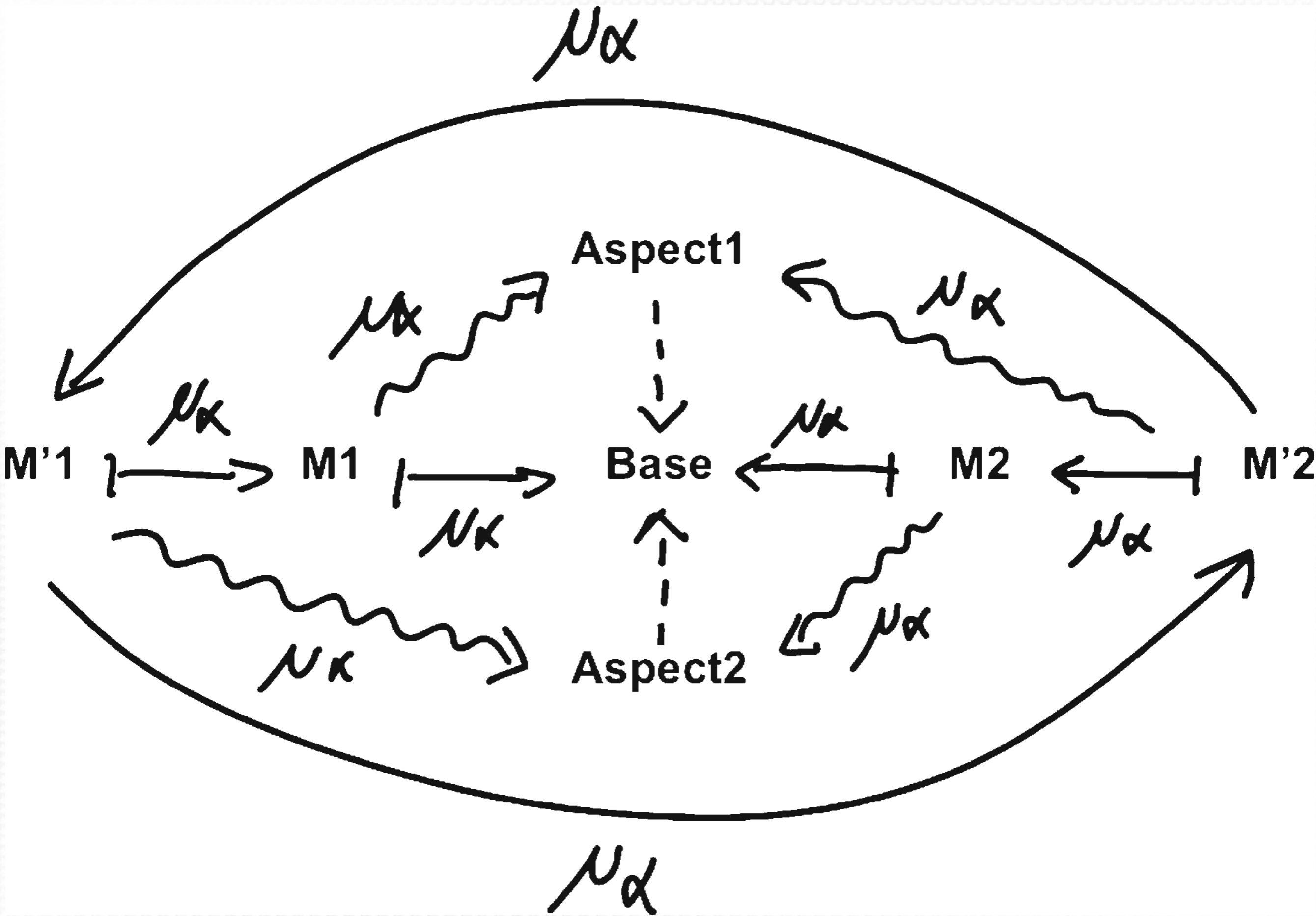



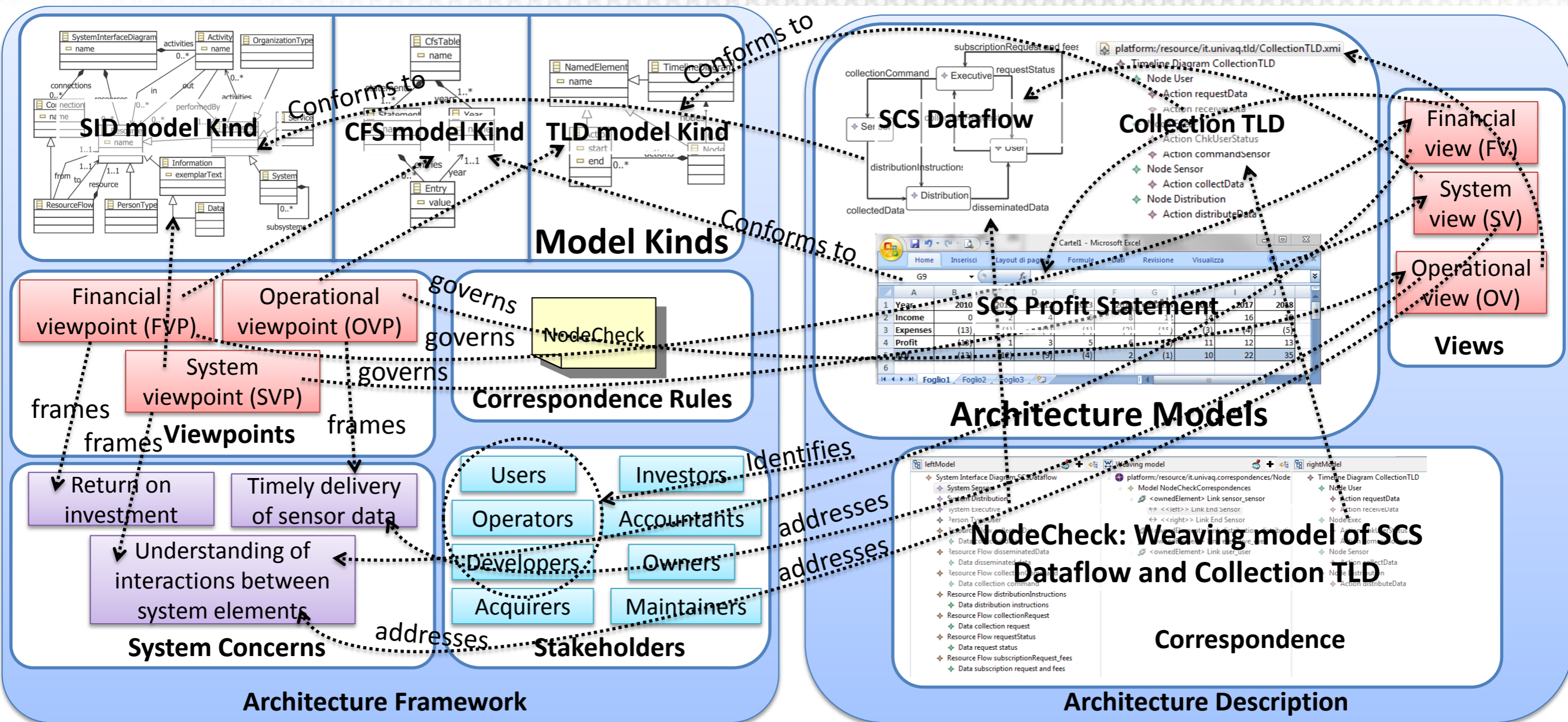

Hilliard, Malavolta, Muccini, Pelliccione. Realizing Architecture Frameworks through Megamodeling Techniques. ASE. 2010.









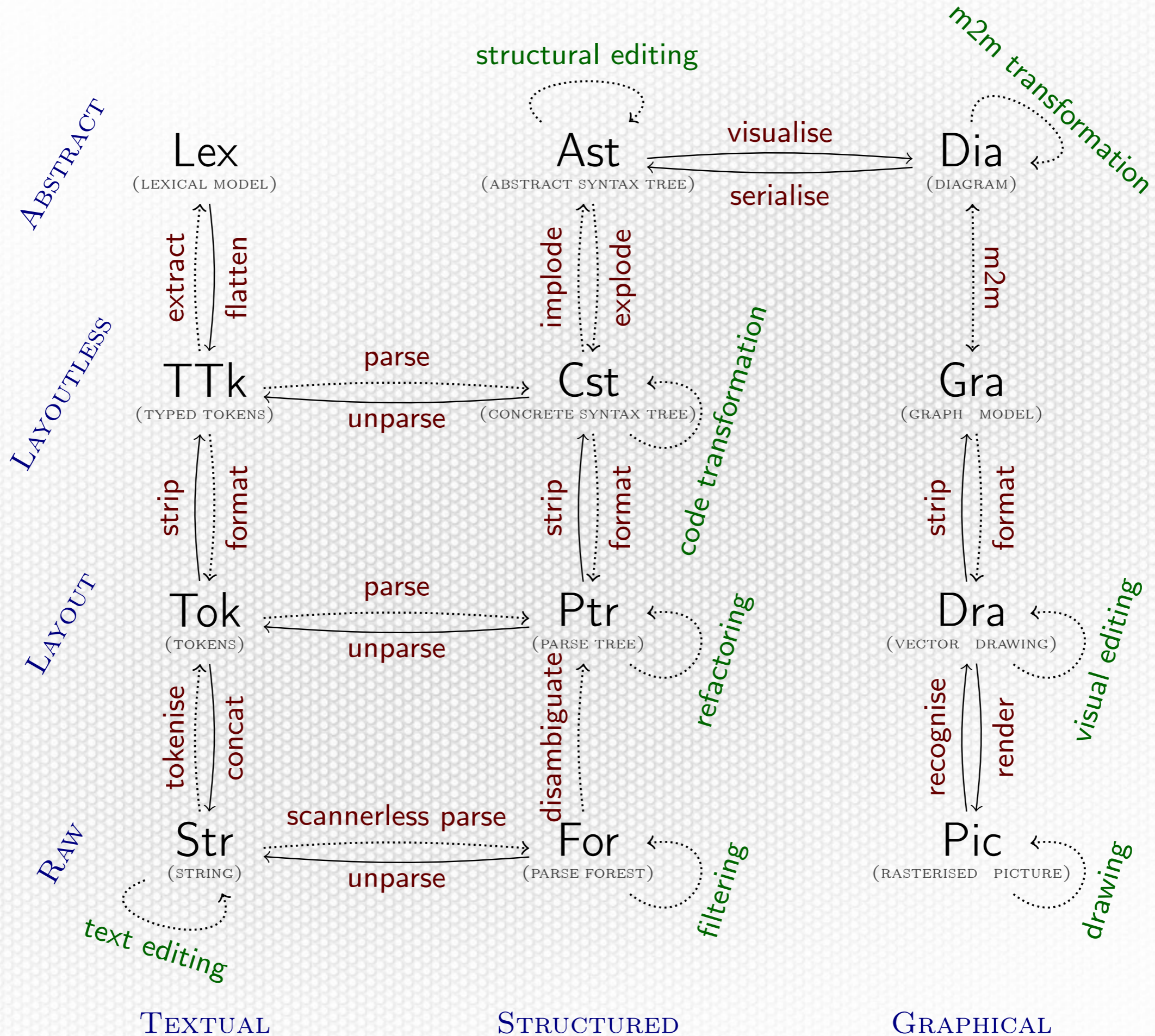







# lex + yacc

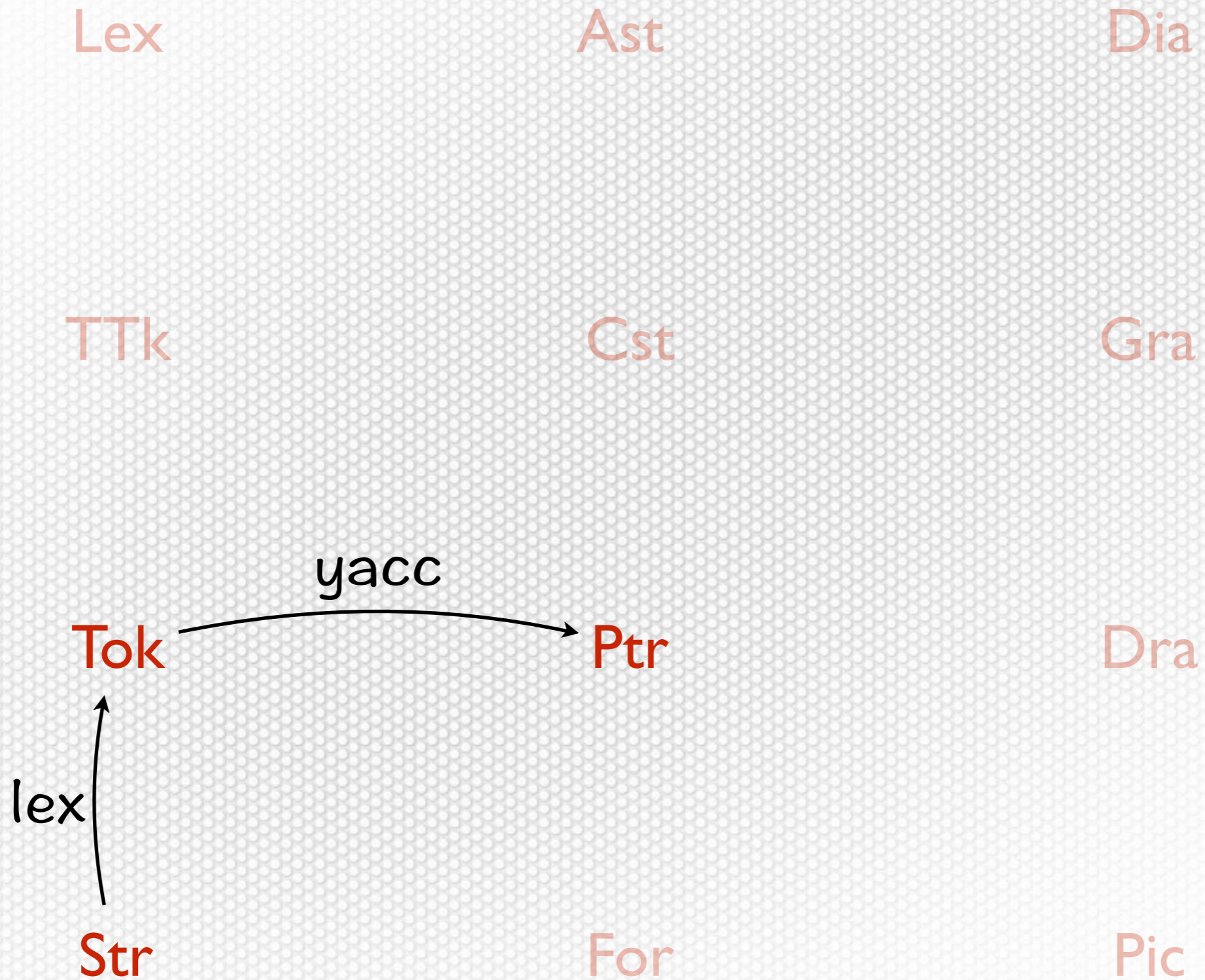

cf. M. E. Lesk, *LEX*, 1975. // S. C. Johnson, *YACC*, 1975.



# ANTLR

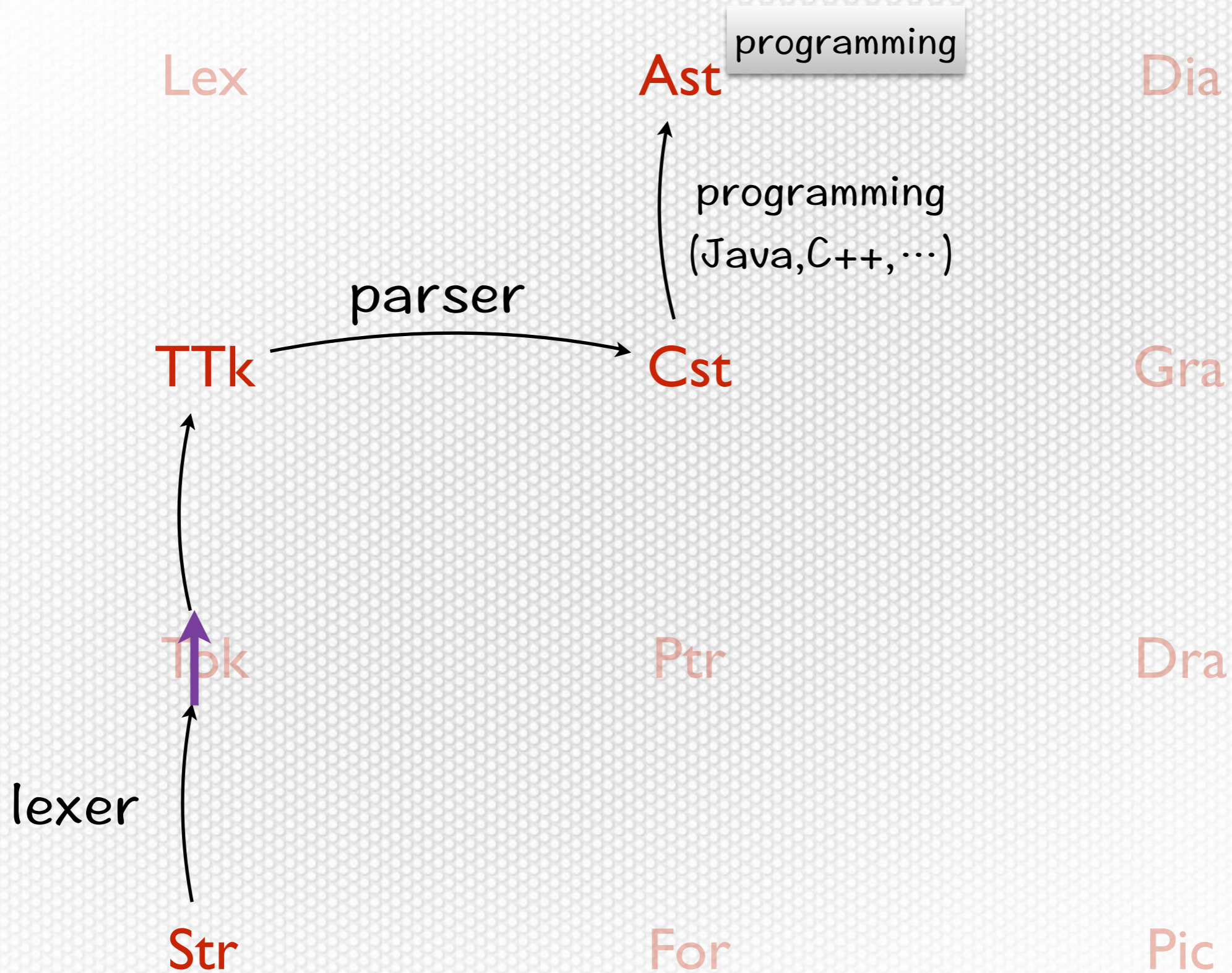

cf. Parr, *Definitive ANTLR Reference*, 2007.



# Rascal one-stop-shop

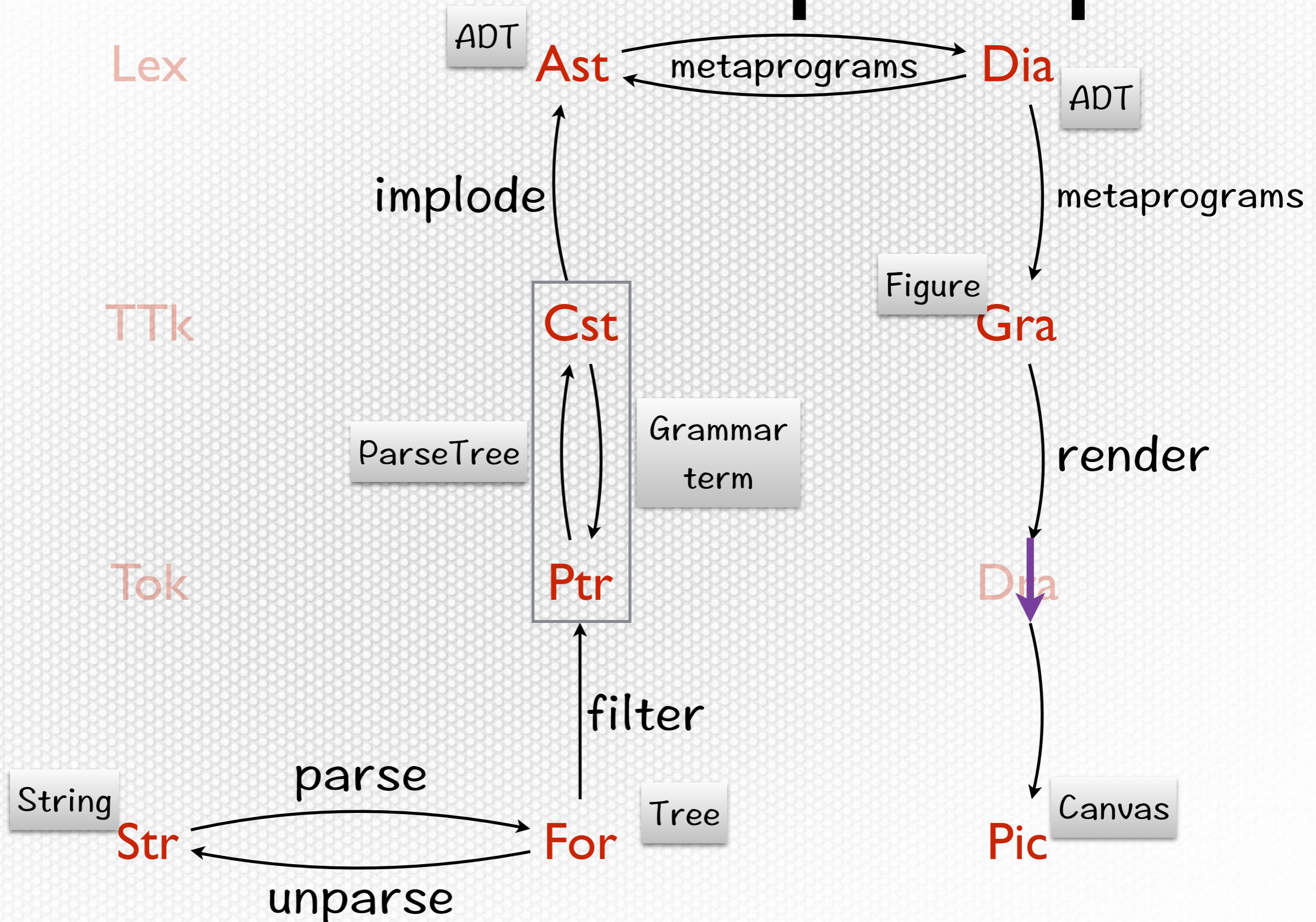

cf. Klint, van der Storm, Vinju, *EASY Meta-programming with Rascal*, GTTSE'09.



# Iterative lexical analysis

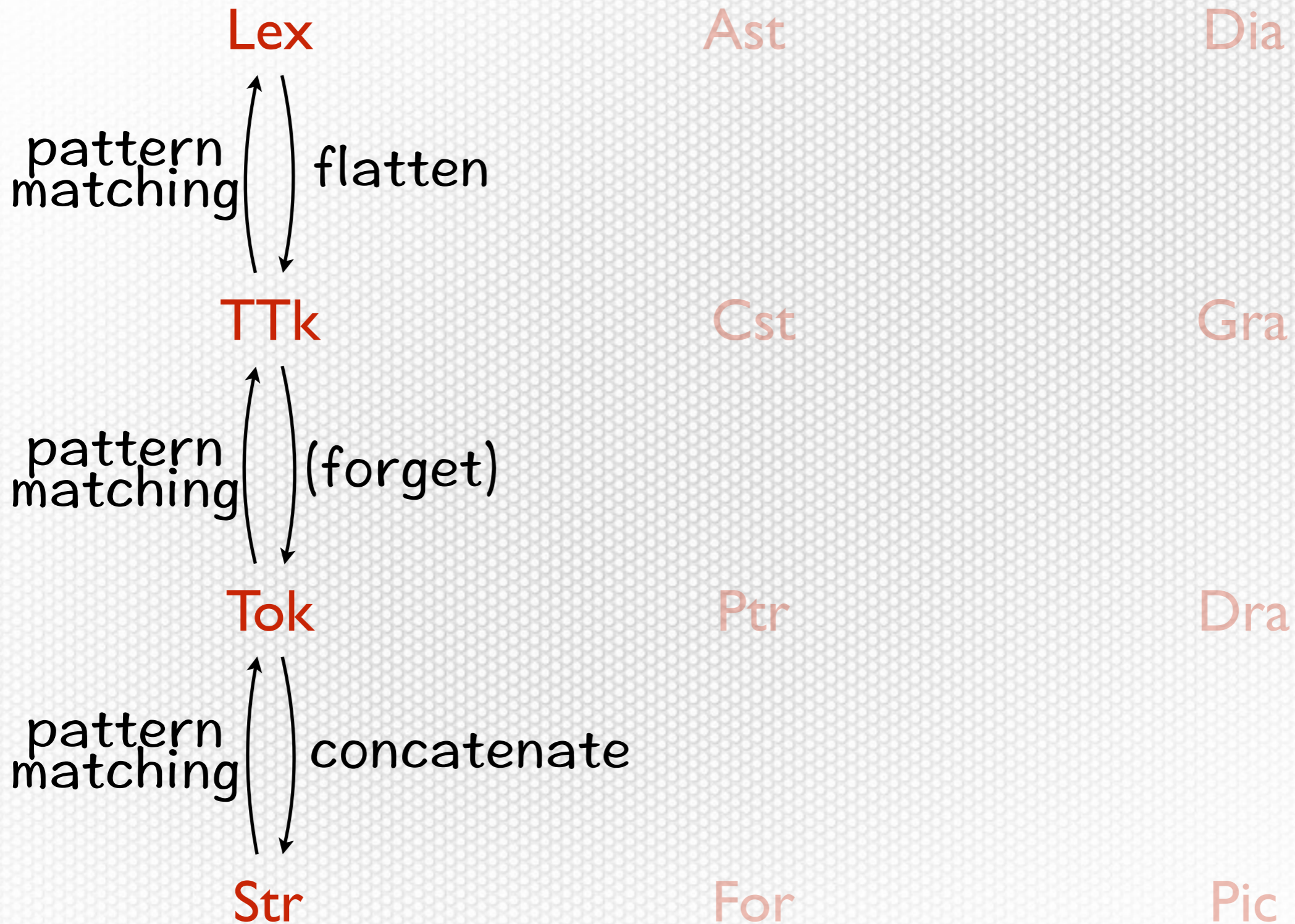























品名：白米